

# Reactive Power Compensation of Grid Connected Wind Turbine by using STATCOM

Nitesh Kumar<sup>1</sup> and Ram Avtar Jaiswal<sup>2</sup>

<sup>1</sup>M.tech-EE UIET, KUK.

<sup>2</sup>EE- Dept. UIET, KUK

E-mail: <sup>1</sup>niteshjatin@gmail.com, <sup>2</sup>ramavtar.jaiswal@gmail.com

---

**Abstract**—As a promising renewable alternative, the wind power is highly expected to contribute a significant part of generation in power systems in the future, but this also bring new integration related power quality issues, which mainly consist of voltage regulation and reactive power compensation. Wind power, as a rule, does not contribute to voltage regulation in the system. Induction machines are mostly used as generators in wind power based generations. Induction generators draw reactive power from the system to which they are connected. Therefore, the integration of wind power to power system networks; especially a weak distribution networks is one of the main concerns of the power system engineers. Voltage control and reactive power compensation in a weak distribution networks for integration of wind power represent main concern of this paper. The problem is viewed from MATLAB/Simulink simulation of weak distribution network and wind power integration in this network. Without reactive power compensation, the integration of wind power in a network causes voltage collapse in the system and undervoltage tripping of wind power generators. For dynamic reactive power compensation, when, STATCOM (Static Synchronous Compensator) is used at a point of interconnection of wind turbine; the system absorbs the generated wind reactive power and used as the active power and maintain the voltage level.

**Keywords:** Induction generators; Reactive power compensation; Wind turbine; STATCOM.

## 1. INTRODUCTION

The installed capacity of wind power in india has 23,440MW (as on March 31, 2015). In terms of wind power installed capacity, India is ranked 5th in the World. Today India is a major player in the global wind energy market. The potential is far from exhausted. Indian Wind Energy Association has estimated that with the current level of technology, the 'on-shore' potential for utilization of wind energy for electricity generation is of the order of 65,000 MW. The unexploited resource availability has the potential to sustain the growth of wind energy sector in India in the years to come. Recently, Government of India has deregularized the power sector. Ministry of New and Renewable Energy (MNRE) has issued guidelines to all state governments to create an attractive environment for the export, purchase, wheeling and banking of electricity generated by wind power projects. Hence,

sustainable growth of wind power generation is expected in the years to come [1]. This growth of wind power generation is likely to influence the operation and planning of the existing power system networks. Because integration of wind power in a power systems resents problem of voltage regulation and reactive power compensation [2]. The wind turbines are composed of an a erodynamic rotor, a mechanical transmission system, squirrel cage induction generator, a control system, limited reactive power compensation and a step-up transformer. The conventional wind turbine is even at the present time, the most common type of wind turbine installed. Therefore, this paper deals about such conventional squirrel cage induction generator system. An important operating characteristic of the squirrel cage induction generator is that this type of generator always consumes reactive power, which is undesirable for the transmission system. Particularly in the case of large turbines and weak distribution system. Another characteristic of the squirrel cage induction generators is that, in general, this type of generator tends to slow down voltage restoration after a voltage collapse and this can lead to voltage and rotor speed instability. When the voltage restores, the generator will consume reactive power, impeding the voltage restoration. When the voltage does not return quickly enough, the generator continues to accelerate and consumes even larger amount of reactive power [2]. This process eventually leads to voltage and rotor speed instability if the wind turbine is connected to a weak system. To prevent these types of instabilities; conventionally, shunt capacitor banks are connected at the generator terminals to compensate its reactive power consumption [3]. To minimize the reactive power exchange between wind farms and distribution network, dynamic compensation of reactive power can be employed [4]. Power electronics based FACTS devices such as SVC and STATCOM are useful for dynamic compensation of reactive power. The STATCOM performs the same function as the SVC. However at voltages lower than the normal voltage regulation range, the STATCOM can generate more reactive power than the SVC. This is due to the fact that the maximum capacitive power generated by a SVC is proportional to the system voltage square (constant

susceptance) while the maximum capacitive power generated by a STATCOM decreases linearly with voltage (constant current) [5]. This ability to provide more capacitive reactive power during voltage collapse is one important advantage of the STATCOM over the SVC. In addition, the STATCOM will normally exhibit a faster response than the SVC because with the VSC, the STATCOM has no delay associated with the thyristor firing. In his paper the reactive power compensation capability of STATCOM for wind turbine integrated into the grid is evaluated. The study is based on the three phase non-linear dynamic simulation, utilizing the Simpower system blockset for the use with MATLAB/Simulink [6].

**2. MODEL DESCRIPTION**

A wind turbine of 4\*1.5MW has been used. Wind turbine use squirrel-cage induction generators (SCIG). The stator winding is connected directly to distributed network. A wind turbines is connected to a 25-kV distribution system exports power to a 120-kV grid through a 30-km 25-kV feeder. The 4\*1.5-MW wind turbine is simulated by to the 60 Hz grid and the rotor is driven by a variable-pitch wind turbine. The pitch angle is controlled in order to limit the generator output power at its nominal value for winds exceeding the nominal speed (9 m/s). In order to generate power the IG speed must be slightly above the synchronous speed. Speed varies approximately between 1pu at no load and 1.005 pu at full load. Each wind turbine has a protection system monitoring voltage, current and machine speed. Reactive power absorbed by the SCIGs is partly compensated by capacitor banks connected to wind turbine low voltage bus. The rest of reactive power required to maintain the 25-kV voltage at B25 bus close to 1pu is provided by a 3-Mvar STATCOM with a 3% droop setting. The turbine mechanical power as function of turbine speed is displayed for wind speeds ranging from 4 m/s to 10 m/s. The nominal wind speed yielding the nominal mechanical power (1pu=3 MW) is 9 m/s. The wind turbine model (from the DR library) and the STATCOM model (from the FACTS library) are phasor models that allow transient stability type studies with long simulation times. In this paper, the system is observed during 20 s. The wind speed applied to turbine is controlled by the wind blocks. Initially, wind speed is set at 8 m/s, then starting at t=2s for "Wind turbine", wind speed is rammmed to 11 m/s in 3 seconds. Then, at t=15 s a temporary line to ground fault is applied at the low voltage terminals (575 V) of "Wind Turbine".

**3. SIMULATION OF MODEL**

Distribution systems are inherently unbalanced in most of the cases due to the asymmetrical line spacing and imbalance of consumer load. In view of this, single phase models cannot be used for accurate studies on the operation of distribution systems[4]. Therefore in this work all network components are represented by the three phase models. Simulation model is simulated in MATLAB/Simulink. Fig.(a) and (b) shows the

Simulink model of the test system. Phasor simulation is used to simulate the test system; so as to make it valid for intended purpose. The simulation time is 10 sec. The simulation is run in two different modes, as follows

- A. Active and Reactive Power Of Wind Turbine Without STATCOM.
- B. Active and Reactive Power Of Wind Turbine With STATCOM.

In each case the pu voltage, active and reactive power at B25 bus are measured. When the STATCOM is connected to the system reactive power supplied by the STATCOM is also measured. For all the measurements, base power taken as 50 MVA and base voltage is 25 kV. Suitable sign convention is followed for measurement and subsequent analysis of active and reactive power.

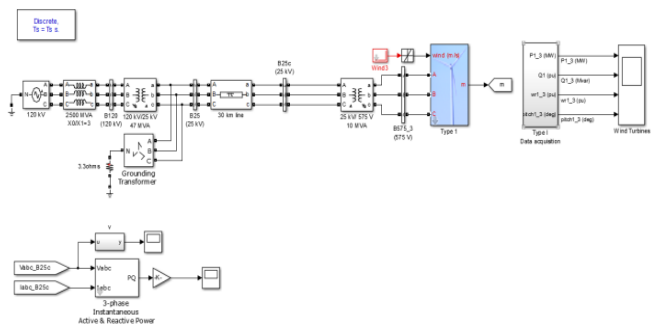

**Fig. 1(a): Simulink Model (without statcom)**

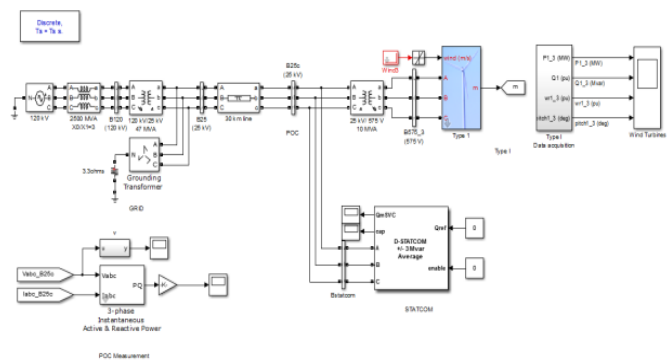
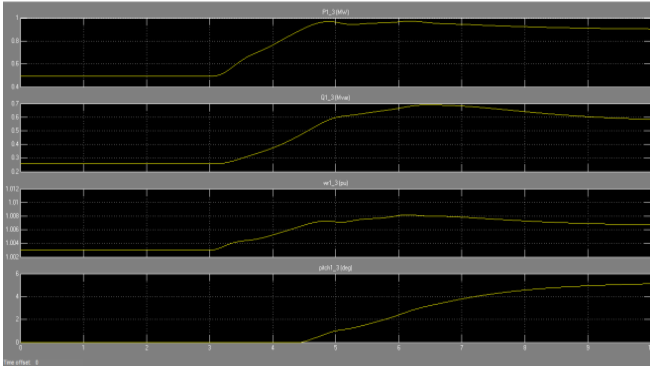

**Fig. 1(b): Simulink Model (with statcom)**

**4. SIMULATION RESULTS**

- A. Active and Reactive Power Of Wind Turbine Without STATCOM

In this mode the STATCOM was skipped while running the simulation. Only the grid system and the wind turbine were kept in the model. The purpose of running the simulation in this mode is to ascertain that, the test system is a weak system. Active and reactive power generated and absorbed by wind turbine is shown Fig.2



**Fig. 2: Active and Reactive Power of wind turbine without statcom.**

### B. Active and Reactive Power Of Wind Turbine With STATCOM

In this mode of simulation the wind turbine with dynamic compensation by STATCOM is connected to the weak distribution network. The purpose of running simulation in this mode is to integrate 9 MW wind power in weak distribution network, with dynamic compensation of reactive power using the STATCOM. Fig.3 shows the , active power supplied and reactive power required by wind turbine generators.

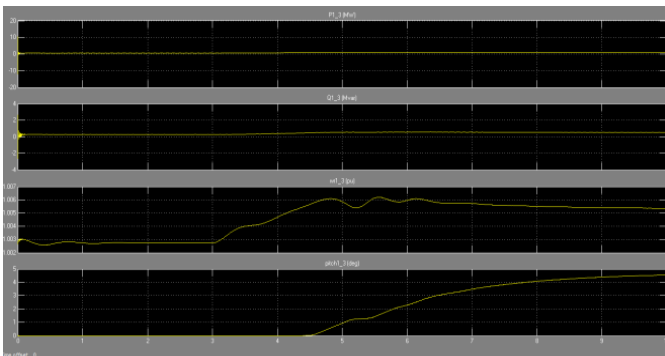

**Fig. 3: Active and Reactive Power of wind turbine with statcom**

From Fig.2 it seen that, in this case the wind turbine generators are not tripped. But they are supplying (3 x 3) MW power to the network. From fig.3 it shows the reactive power supplied by the STATCOM. It is seen that initially wind when the starting speed of turbine generators is low turbine generator draws less reactive power and it increases with speed. After 8 second later the reactive power demand is stabilized at (1.5 x 4) Mvar.

## 5. CONCLUSION

In this paper, we study the active and reactive power management of wind turbine and compare the output of the controller with and without statcom. In this paper STATCOM is used for reactive power compensation on grid connected

wind turbine. A static synchronous compensator (STATCOM) is a regulating device used on alternating current electricity transmission networks. It is based on a power electronics voltage-source converter and can act as either a source or sink of reactive AC power to an electricity network. Usually a STATCOM is installed to support electricity networks that have a poor power factor and often poor voltage regulation. The major attributes of STATCOM are quick response time, less space requirement, optimum voltage platform, higher operational flexibility and excellent dynamic characteristics under various operating conditions.

## REFERENCES

- [1] Y. Cheng, C. Qian, M. L. Crow, S.Pekarek,S. Atcity, "A Comparison of Diode Clamped and Cascaded Multilevel Converters for a STATCOM with Energy Storage," IEEE Trans.on Industrial Electronics, Vol. 53, No. 5, pp.1512-1521,2006
- [2] Chaudhary, S., Teodorescu, R., and Rodriguez, P. Wind farm grid integration using vsc based hvdc transmission - an overview. IEEE Energy2030 Atlanta, GA USA (2008).
- [3] M.G. Molina and P.E. Mercado, Control Design and simulation of D-STSTCOM with energy storage for Power Quality improvements", in Proc. IEEE/PES trans.4Distrib.L.A. Caracon, Venezuela,2006.
- [4] Jianye Cuen, Shan Song, Zanjwang, " Analysis and implement of Thyristor based STATCOM", 2006, International conference on Power System technology.
- [5] Mehdi Hosseini, Mahmoud Fotuhi Firuzabad, "Modeling of series and shunt distribution FACTS Device in distribution system load flow", J.Electrical Systems 4-4(2008), 1-12. N.G.Hingorani, L.Gyugi: Understanding FACTS. Concepts and Technology of Flexible AC Transmission Systems. IEEE Press, New York, 2000.
- [6] C. Schauder, "STATCOM for Compensation of Large Electric Arc Furnace Installations," Proceedings of the IEEE PES Summer Power Meeting, Edmoton, Alberta, July 1999, pp.1109-1112.
- [7] G. Reed, J. Paserba, T. Croasdaile, M.Takeda, Y. Hamasaki, T. Aritsuka, N. Morishima, S.Jochi, I. Iyoda, M. Nambu, N. Toki, L. Thomas, G. Smith, D.LaForest, W. Allard, D.Haas, "The VELCOSTATCOM-Based Transmission System Project," Proceedings of the 2001 IEEE PES Winter Power Meeting, Columbus, H, January/February 2001.
- [8] C. Schauder, "STATCOM for Compensation of Large Electric Arc Furnace Installations," Proceedings of the IEEE PES Summer Power Meeting, Edmonon, Alberta, July 1999. pp.1109-1112.